

Vitalograph[®]

VitaloJAK

MODEL 7100

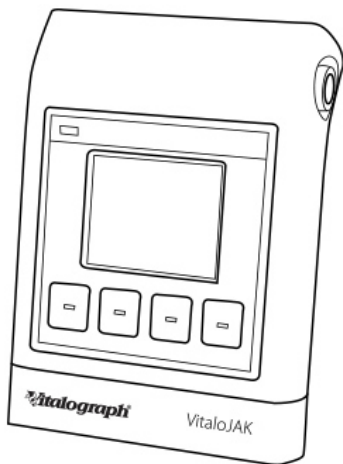

CE
2797

Rx Only

Instructions for Use

Vitalograph Branch Addresses

UK REP Vitalograph Ltd, UK
Maids Moreton, Buckingham
MK18 1SW
England
Tel: 01280 827110
E-mail: sales@vitalograph.co.uk
www.vitalograph.com
Technical Support
Tel: 01280 827177
Email: technical.support@vitalograph.co.uk

 **Vitalograph GmbH**
Rellinger Straße 64a
D-20257 Hamburg
Germany
Tel: +49 40 547391-0
Fax: +49 40 547391-40
E-mail: info@vitalograph.de
www.vitalograph.com
Technical Support
Telefon: +49 40 547391-14
E-mail: technical.support@vitalograph.de

 **Vitalograph (Ireland) Ltd**
Gort Road Business Park
Ennis, Co Clare, V95 HFT4
Ireland
Tel: +353 65 6864100
Fax: +353 65 6829289
E-mail: info@vitalograph.ie
www.vitalograph.com
Technical Support
Tel: +353 65 6864111
Email: technical.support@vitalograph.ie

Vitalograph Inc.
13310 West 99th Street
Lenexa, Kansas, 66215
USA
Toll Free: 1-800 255 6626
Tel: (913) 730 3200
E-mail: contact@vitalograph.com
www.vitalograph.com
Technical Support
Tel: (913) 730-3205
Email: technical.support@vitalograph.com

© Copyright Vitalograph 2026
Current Edition (Issue 4, 28-May-2026)
Cat. No. 09260

 is a registered trademark.

Contents

| | |
|---|----|
| 1. Intended Use/Indications for Use: | 4 |
| 2. Contraindications, Adverse Reactions, Warnings and Precautions. | 4 |
| 2.1. Contraindications and Adverse Reactions | 4 |
| 2.2. Warnings and Precautions | 5 |
| 3. Main Components of the Vitalograph Model 7100 VitaloJAK... 8 | |
| 3.1. Features of the Vitalograph Model 7100 VitaloJAK | 9 |
| 4. Setting Up the Vitalograph Model 7100 VitaloJAK | 10 |
| 4.1. Connecting the VitaloJAK to a PC | 10 |
| 4.2. Fitting a New Battery Pack..... | 11 |
| 4.3. Connecting the Air Microphone and Chest sensor | 12 |
| 4.4. Setup Menu | 13 |
| 5. Operating Instructions..... | 14 |
| 5.1. Positioning the Air Microphone and Chest Sensor | 14 |
| 5.2. Starting and Stopping a Recording..... | 15 |
| 5.3. Subject Instructions..... | 17 |
| 5.4. Finishing a Cough Recording | 18 |
| 5.5. Uploading Data..... | 19 |
| 6. Power Management | 20 |
| 7. Cybersecurity Considerations..... | 20 |
| 7.1. Specification | 20 |
| 7.2. Security Recommendation | 20 |
| 7.3. Interfaces | 21 |
| 8. Cleaning & Hygiene..... | 21 |
| 9. Fault Finding Guide..... | 22 |
| 9.1. Software Check..... | 26 |
| 9.2. Product Useful Life Check..... | 26 |
| 10. Customer Service | 27 |
| 11. Consumables and Components | 27 |
| 12. Disposal Instructions..... | 27 |
| 13. Explanation of Symbols | 28 |
| 13.1. Graphical User Interface Symbols | 30 |
| 13.2. Additional Symbols Used on Device..... | 31 |
| 14. Description of the Vitalograph Model 7100 VitaloJAK | 31 |
| 15. Technical Specifications | 32 |
| 16. Electromagnetic Compatibility (EMC) Standards..... | 34 |
| 17. FDA Notice | 37 |
| 18. Regulatory information | 38 |
| 19. Guarantee..... | 39 |

1. Intended Use/Indications for Use:

The VitaloJAK model 7100 is a non-invasive battery operated device intended to acquire, record and store ambulatory cough sounds from patients for up to 24 hours. The device stores the data on internal or removeable memory card media for later playback, review, and analysis on a windows based PC.

The VitaloJAK is indicated for use in cough recording sessions. It provides the means to sense voice and cough activity from a subject, record this information and store it on an SD memory card. The VitaloJAK is not life supporting equipment, it does not screen, treat or prevent any condition or disease. The subjects may be of any user population, weight range, health, or condition.

2. Contraindications, Adverse Reactions, Warnings and Precautions.

2.1. Contraindications and Adverse Reactions

2.1.1. Contraindications

1. When fitting the cable to the subject any excess cable must be secured using the tape provided to avoid a strangulation hazard. Children must be supervised when wearing the VitaloJAK.
2. Care should be taken with the microphone clip, which is detachable and may become a choking hazard if swallowed. Children must be supervised when wearing the VitaloJAK.
3. Care should be taken when the technician is removing the battery door. When removed, it has the potential to provide discomfort to the technician setting up the device if aggressively pressed against the skin.

2.1.2. Adverse Reactions

1. If the VitaloJAK chest sensor is being replaced with a new sensor the healthcare professional should inspect the

condition of the skin for damage/tearing/stripping. A new sensor should not be applied if damage is evident. Slight redness can be expected as with the removal of any plaster/band aid or adhesive dressing.

2.2. Warnings and Precautions

1. No modification of this equipment is allowed. Any unauthorised changes to the VitaloJAK may compromise product safety and/or data and as such Vitalograph cannot be held responsible and the device will no longer be supported.
2. The VitaloJAK has no serviceable parts. The device must be returned to the manufacturer at the end of the Study.
3. Repairs should only be carried out by the manufacturer.
4. The VitaloJAK is not designed as a sterile device. Always follow the safety guidelines given by the manufacturer of cleaning and disinfectant chemicals.
5. A new chest sensor should be used for each subject. Do not remove the chest sensor at any time during the recording. If an attempt is made to re-use or re-attach a chest sensor the adhesive will no longer be effective, the chest sensor may fall off and the data may be compromised.
6. Ensure the device is not attached to the subject and is powered down prior to replacing the cough sensor/microphone cable assembly.
7. A new battery pack should be fitted for each new recording to achieve the full 24-hour recording. If a partially discharged battery pack is used the 'Battery Low' error will display. Ensure the device is not attached to the subject and is powered down prior to replacing the battery pack.
8. The VitaloJAK should be powered down and not attached to the subject prior to fitting or removing the SD card.
9. When connected to a PC, do not disconnect the device from the PC until the Webportal indicates it is safe to do so. Failure to do so could corrupt or damage the device internal memory or SD card.
10. Contact the site administrator/study coordinator if the chest sensor becomes detached, if the VitaloJAK alarms

during the recording or any other problems occur as the recording may be affected.

11. It is recommended to use water or saline solution to soften the adhesion of the hydrocolloid on the sensor tape, thus making removal easier, and reducing the risk of skin damage.
12. Ensure the audio microphone is not covered or rubbed by clothing, which may interfere with the recording.
13. The device contains a Lithium coin cell battery which is not accessible by the user and is not a serviceable part.
14. Maintenance must not be performed while the device is in use by a patient.
15. Do not get the device wet. The device must not be worn in the shower. The cough sensor must not be worn in the shower during a recording, it may be worn in the shower after a recording is complete and when disconnected from the device, to make removal easier.
16. Wear the device in bed overnight by wearing the pouch supplied or alternatively placing the device on the bedside locker. Clip the audio microphone to the lapel of night clothes or pillow case.
17. The battery pack should be removed from the VitaloJAK if the device is intended to be stored, without use, for an extended period of time.
18. Do not disconnect the device or USB cable from the PC during data transfer.
19. Only approved components and consumables from the manufacturer should be used with the VitaloJAK. It may be unsafe to use components and consumables, detachable parts and materials not described in this document.
20. The VitaloJAK should always be used in the supplied pouch when completing a recording. This ensures the device remains recording for the duration, reduces the effect of environmental conditions from lint, dust, ESD.
21. Avoid noisy environments while wearing the VitaloJAK. For example, the cinema, driving with the windows down, the gym or using the hair dryer which may interfere with the recording.

22. Portable RF communications equipment (including peripherals such as antenna cables and external antennas) should be used no closer than 30 cm (12 inches) to any part of the VitaloJAK including cables specified by Vitalograph. Otherwise, degradation of the performance of this equipment could result.
23. Use of this equipment adjacent to or stacked with other equipment should be avoided because it could result in improper operation. If such use is necessary, this equipment and the other equipment should be observed to verify that they are operating normally.
24. For home use subjects: If there are any changes in the performance of the equipment contact the site study administrator.
25. Avoid near active high frequency surgical equipment and the RF shielded room of an ME system for magnetic resonance imaging, where the intensity of electromagnetic disturbance is high.
26. In the unlikely event that there is any visible damage to the battery pack contact Vitalograph 24/7 support immediately.
27. Reprocessing of single use devices is not permitted.
28. The VitaloJAK should not be used in the presence of flammable liquids or gases, dust, sand or any other chemical substances.

3. Main Components of the Vitalograph Model 7100 VitaloJAK

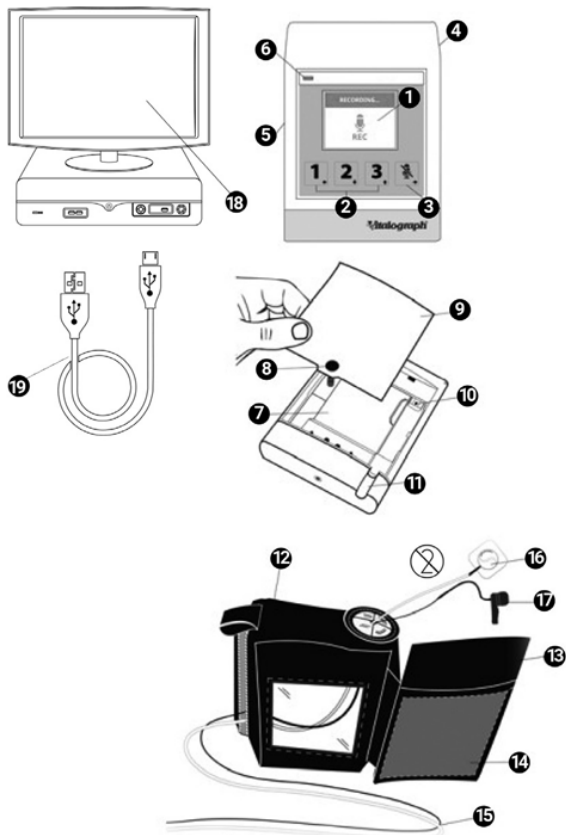

Figure 1: Main Components of the VitaloJAK

The main components are:

| | |
|----|-----------------------------------|
| 1 | LCD screen |
| 2 | Event Buttons 1, 2 and 3 |
| 3 | Mute / Privacy Button |
| 4 | Keyswitch |
| 5 | SD Card Slot |
| 6 | LED Light |
| 7 | Battery Compartment |
| 8 | Back Cover Screw |
| 9 | Back Cover |
| 10 | Cable Connector |
| 11 | Channel for Cable |
| 12 | Pouch |
| 13 | Pouch Flap |
| 14 | Pouch Insert |
| 15 | Sensor Cable |
| 16 | Chest Sensor |
| 17 | Air Microphone |
| 18 | PC running Vitalograph Web Portal |
| 19 | USB Data Cable |

3.1. Features of the Vitalograph Model 7100 VitaloJAK

The features include:

- Use of cough sensor for cough detection
- Second audio recording using a lapel microphone for validation purposes
- Real time clock
- Wearable pouch for portability
- Battery operated
- Power on/off requires a key

4. Setting Up the Vitalograph Model 7100 VitaloJAK

The Vitalograph VitaloJAK is designed to be used with the Vitalograph Webportal accessed via a PC, for setup and recording retrieval.

To get the VitaloJAK ready for use:

- Check that the contents of the packaging correlate with the site and test kit contents specified in the site manual.
- Check the serial numbers of the VitaloJAK, Site Kit and Test Kits against the packing list in your shipment. Serial numbers should match.
- Please read, retain and refer to all study material, product information and instruction manuals that are sent to you.

4.1. Connecting the VitaloJAK to a PC

1. Follow the site manual instructions to access the Webportal.
2. If the device is powered on, use the key to turn it off prior to connecting it to the PC. The red dot on the keyswitch should line up with the 'O' mark on the case when the device is powered off.
3. Unscrew the back cover of the device using screwdriver provided. Remove the back cover.
4. If the device has previously been used, remove the microphone and chest sensor wire and battery, following instructions at Section 5.4 and 5.5. Before setting up the VitaloJAK for a different subject, clean the device according to cleaning and hygiene instructions at Section 8.
Note: The data cable, check sensor/air microphone and battery pack connectors have a locking mechanism to stop accidental disconnection or damage.
5. For studies using a removable SD card instead of the internal flash memory, an SD card should be inserted at this stage using SD Card Tool provided.
6. Connect one end of the data cable to the device via the cable connector (Figure 2) and the other to the PC used to access the Webportal. The battery should be detached when the VitaloJAK is connected to the web portal.
7. Follow the instructions on the Webportal.

Note: Do not configure the device for a subject until a recording is due to take place.

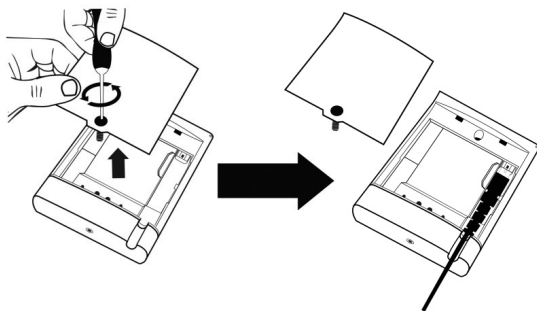

Figure 2: Removing the Back Cover for Connection of the Data Cable

4.2. Fitting a New Battery Pack

A new battery pack is required for each recording session. When replacing the battery pack, the device should be powered down and should not be attached to the subject. If attached to a PC, disconnect the USB cable from the device.

1. Unscrew the back cover of the device using screwdriver provided and remove.
2. If the device contains a used battery pack, remove this by pushing down on the battery pack release catch and pulling back on the battery connector.

Note: The battery pack connector has a locking mechanism to stop accidental disconnection or damage. The release catch must be pushed down to remove.

3. To insert a new battery pack, connect the battery pack connector into the battery connection point on the device.

Note: In the unlikely event that there is any visible damage to the battery pack, please contact Vitalograph 24/7 Support immediately. Do not use damaged battery packs.

4. Fit the battery pack inside the battery compartment.
5. Proceed to instructions for connecting the air microphone and chest sensor.

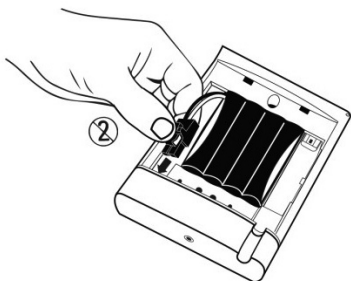

Figure 3: Fitting the Battery Pack

4.3. Connecting the Air Microphone and Chest sensor

1. Ensure the device is not attached to the subject and is powered down.
2. Feed a new chest sensor and air microphone cable into the pouch via the cable feed at the top.
3. Plug the chest sensor and air microphone cable into the data cable connector on the device.

Note: The cable connector has a locking mechanism to stop accidental disconnection or damage. To disconnect, use one hand to slide forward the data cable release catch while pulling back on the connector to release the data cable with the other hand.

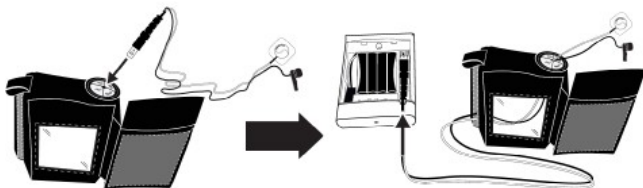

Figure 4: Connecting the Air Microphone and Chest Sensor

4. Attach the back cover and fasten it closed with the screw.



Figure 5: Reattaching the Back Cover

4.4. Setup Menu

The keypad on the front of the device is used to navigate through the device menus. The arrow symbols indicate the function of each key for menu navigation as shown in Figure 6:

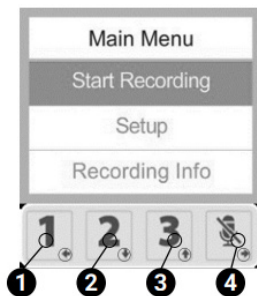

Figure 6: Menu Navigation using the Keypad

| | |
|---|--|
| 1 | Return to Previous Menu |
| 2 | Navigate down between options |
| 3 | Navigate up between options |
| 4 | Enter current selection/ Mute when recording |

Turn the device on using the key. The red dot on the keyswitch should line up with the 'I' mark on the case when the device is powered on.

1. When the Main Menu is displayed select 'Setup'.
2. On Setup Menu select 'Audio Level'.
3. On Audio Levels screen ensure both the Chest Sensor 'C' and Air Microphone 'A' bar graphs are responding to sound.

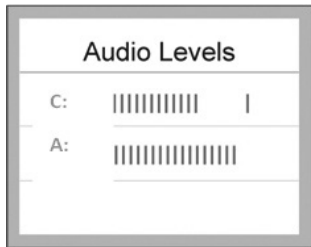

Figure 7: Audio Levels

4. Return to Setup Menu. Select 'Date & Time'.
5. Check date and time are correct. Adjust if necessary.
6. Return to Main Menu.

5. Operating Instructions

5.1. Positioning the Air Microphone and Chest Sensor

A new air microphone and chest sensor should be used for each subject/test.

Note: The microphone and sensor are to be positioned immediately prior to starting the recording.

1. Prepare the area ensuring it is dry, free from excess hair, jewellery and tight clothing.
2. If the chest sensor is being replaced with a new sensor the healthcare professional should inspect the condition of the skin for damage or irritation.

Note: A new sensor should not be applied if damage or irritation to the skin is evident. Slight redness can be expected as with the removal of any plaster or adhesive dressing.

3. Feed the lapel microphone and chest sensor wires underneath clothing, up to the collar.

4. On the chest sensor, peel back the larger portion of the protective covering.
5. Adhere the chest sensor to the subject so that the sticky pad touches the bottom of the suprasternal notch and the sensor wire hangs down. The suprasternal notch is a large, visible dip located between the neck and the collarbone.
6. Remove the remaining protective covering from the sensor sticky pad.
7. Clip the microphone to the outside of the subject's clothing between 4 and 6 inches (10cm and 15cm) away from the subject's mouth.

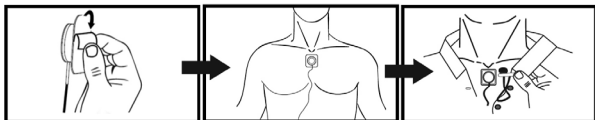

Figure 8: Positioning the Chest Sensor and Air Microphone

8. Use the tape provided to secure the chest sensor wire in place. This will prevent excess cable from pulling on the sensor causing it to become detached.

Note: When fitting the cable to the subject, the microphone clip and any excess cable must be secured to avoid a choking hazard from the clip and to mitigate strangulation risk from excess cable. Children must be supervised while wearing the VitaloJAK.

5.2. Starting and Stopping a Recording

1. Ensure that the chest sensor/microphone cable is connected and a new battery pack is inserted as per Section 4, Set Up.
2. Power on the device using the key. The red dot on the keyswitch should line up with the 'I' mark on the case when the device is powered on.
3. When the Main Menu is displayed, select 'Start Recording'.



Figure 9: Main Menu

- The Subject ID screen is displayed. Confirm subject and visit details.

Note: If any of the subject or session details are incorrect, refer to the site manual for guidance.

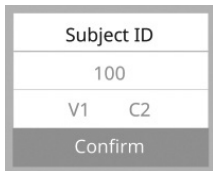

Figure 10: Subject ID

- The Date & Time screen is displayed. Confirm date and time are accurate.

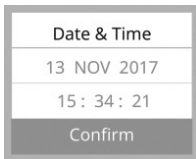

Figure 11: Date and Time Conformation

- The Recording Duration Screen is displayed. Confirm the recording duration to begin the recording.



Figure 12: Recording Duration Screen

7. The 'Recording' screen is displayed briefly per Figure 13, before going blank.

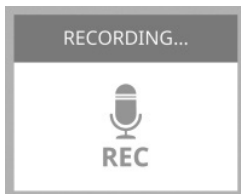

Figure 13: Recording Screen

8. Verify recording has started by confirming the screen is blank and the LED light on the front of the device is flashing green.
9. Place the device into the pouch then fasten it around subject's waist and provide guidance to subject for recording period. To prevent tampering, the pouch may be secured with a zip tie.
10. The device automatically powers down after the full recording is complete. No user interaction is required.

5.3. Subject Instructions

Requirements for subject use of the VitaloJAK device are study specific and are detailed in the Site Manual per study. The following are design features/requirements of the VitaloJAK:

1. The subject may press event buttons to register events during the recording session, or to mute the device, as instructed by the technician.
2. The subject may unclip or adjust the pouch if required for

comfort but may not remove the device from the pouch. The zip tie fitted on the pouch may only be fitted and removed by the healthcare professional. If required for comfort overnight, the pouch may be placed on a bedside locker, with the audio microphone clipped to the lapel of the user's nightclothes or edge of the pillowcase.

3. The chest sensor must remain in place for the entire recording period.
4. The device must be kept dry.
5. The VitaloJAK, chest sensor and air microphone must not be worn in the shower or bath during a recording.
6. The subject should try to avoid noisy environments while wearing the VitaloJAK device. For example, the cinema, driving with the windows down, the gym, or using the hair dryer.

5.4. Finishing a Cough Recording

1. The device automatically powers down after the full recording is complete. (Duration is set according to the study requirement).
2. When recording has stopped the screen displays 'COMPLETE' for 5 seconds and shows recording duration in the format hh:mm:ss. The LED light on the front of the device shows a solid green light.
3. The VitaloJAK device must be checked on return to the clinic to ensure the recording has stopped.

Note: *The device, chest sensor and air microphone may only be removed from the subject when the indicator light is solid green.*

4. Unclip the air microphone from the subject's clothing and detach the chest sensor.

Note: *Using clean water or saline solution softens the adhesion of the hydrocolloid on the chest sensor and tape, making removal easier and reducing the risk of skin damage.*

5. Remove the VitaloJAK from the pouch and turn off the device by turning the key so that the red dot on the keyswitch lines up with the 'O' mark on the case.
6. When the device is not attached to the subject and is

powered down, unscrew the back cover of the device using screwdriver provided and remove.

7. To disconnect the sensor/microphone cable, slide forward the cable release catch while pulling back on the connector to release the cable.

Note: Removal of the USB Cable/ Chest Sensor and Microphone/ Battery pack from the VitaloJAK should NOT require excessive force. Please push down on the release catch before removing.

8. If an SD card was used, follow site instructions regarding use of the SD card.

5.5. Uploading Data

1. Disconnect the battery pack by pushing down on the battery pack release catch and pulling back on the battery connector to remove.
2. Using the USB cable supplied, connect the VitaloJAK to a PC running the Webportal to upload data. Follow the instructions in the site manual and the web portal wizard. The battery should be detached when the VitaloJAK is connected to the Webportal.

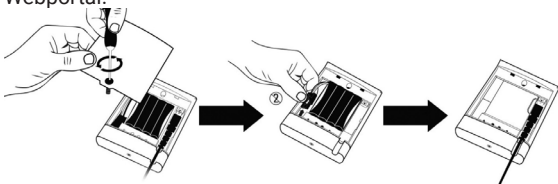

Figure 14: Removing the battery pack and connecting the USB cable

3. When the data has uploaded, disconnect the USB cable from the PC and then detach it from the device by sliding forward the release catch while pulling back on the connector to release the cable.

Note: The used chest sensor and battery pack should be retained until the recording has been analysed. See instructions in Section 12, Disposal.

6. Power Management

The VitaloJAK is powered by a battery pack, comprising 3 x AA batteries, which should be replaced prior to configuring the device for each recording session. Ensure the device is not attached to the subject when changing the battery pack.

- When powered on and not recording, the Power LED is GREEN.
- When powered on and recording, the Power LED flashes GREEN.
- When an error state exists, the Power LED flashes RED.

If the battery pack is low on power, the device reports a Low Battery fault, the Power LED flashes RED and the device will not operate. See Section 9, Fault Finding Guide.

Before turning off the device, first allow any recordings to complete to avoid data loss. Then turn off the device by turning the key so that the red dot on the keyswitch lines up with the 'O' mark on the case.

To turn on the device, turn the key so that the red dot on the keyswitch lines up with the 'I' mark on the case.

7. Cybersecurity Considerations

Cyber Security Standards: IEC 81001-5-1 and IEC 60601-4-5

7.1. Specification

The Device does not have an operating system so is not susceptible to malwares. Access to the data on the device is protected. The Password required to access the device communications protocol shall be encrypted to AES-256 standard based on the device serial number. A propriety USB cable is required. Only Vitalograph PC based applications can access the device over a secure connection. No further controls are required to be applied by users to secure the device.

7.2. Security Recommendation

When connecting to a PC it is recommended that the PC has the following cybersecurity in place:

- **Up to date Operating System:** the Operating System should be configured for automatic update for security patches and have all of the latest patches applied.

- **Antivirus/antimalware:** the PC should have a reputable antivirus or antimalware application installed and all updated virus definitions in place.
- **Secure Login:** the PC should be password protected via industry standard user access controls, via active directory or other methods.
- **Firewall:** if the PC is connected to the internet ensure a reputable firewall or equivalent protection is in place to protect against unauthorised external access.

7.3. Interfaces

Communications interfaces – USB: The device will communicate with Vitalograph PC based applications for:

- Device configuration
- Transfer of data

8. Cleaning & Hygiene

The VitaloJAK is not designated as a sterile device.

A new chest sensor/air microphone assembly must be used for each subject/test.

The body of the device may be cleaned with a 70% isopropyl alcohol wipe. Cleaning should be completed between subjects/ recordings to reduce risk of cross contamination.



The VitaloJAK pouch should be replaced if visibly soiled.



Table of Cleaning/Disinfection Methods



| Part | Clean/Low Level Disinfection | Recommended Cleaning/ Low Level Disinfection |
|---------------|------------------------------|--|
| Case exterior | Clean | Wiping with a 70% isopropyl alcohol impregnated cloth provides a suitable form of cleaning and disinfection. |



9. Fault Finding Guide

Site manuals contain details for study site actions on encountering a fault with the VitaloJAK. The following are generic fault symptoms and possible solutions.

| | |
|--|---|
| Problem Fault Symptoms: | <ul style="list-style-type: none"> • Device does not power on • Device powers on but does not stay on or is not operational, e.g. can't select a menu item or the LCD display is corrupted. |
| Possible Solutions: (In probable order) | <ul style="list-style-type: none"> • The battery pack may be low/dead, replace battery pack. A new battery pack is required for each recording session. • Electronics failure - contact support. |
| Problem Fault Symptoms: | <ul style="list-style-type: none"> • Memory error symbol displays and LED flashes RED.  |
| Possible Solutions: (In probable order) | <ul style="list-style-type: none"> • Data has not written to memory. Shutdown the device and contact support. |
| Problem Fault Symptoms: | <ul style="list-style-type: none"> • Battery Low Error symbol displays and the LED flashes RED.  |
| Possible Solutions: (In probable order) | <ul style="list-style-type: none"> • Replace the battery pack. A new battery pack is required for each recording session. |
| Problem Fault Symptoms: | <ul style="list-style-type: none"> • The Idle Alert symbol (Amber) displays and buzzer beeps loudly.  |

| | |
|--|--|
| Possible Solutions: (In probable order) | <ul style="list-style-type: none"> The device has been left idle for more than 5 minutes while powered on and without starting a recording, press Select (forward keypad arrow) to resume normal operation. |
| Problem Fault Symptoms: | <ul style="list-style-type: none"> Insert cable symbol displays and the LED flashes RED.  |
| Possible Solutions: (In probable order) | <ul style="list-style-type: none"> The cable is not connected correctly to the device. Check the cable connection. The cable is faulty. Replace the cable. |
| Problem Fault Symptoms: | <ul style="list-style-type: none"> Attach cover warning displays and the LED flashes RED.  |
| Possible Solutions: (In probable order) | <ul style="list-style-type: none"> The back cover of the device is not securely attached to the device. Check that the screw is sufficiently tightened (do not overtighten). The door sensor has developed a fault, contact support. If not recording, normal operation will resume when the back cover is reattached. If recording, the recording stops with this warning and an error is logged to the audit trail. Subjects should contact their Site Administrator. Site Administrator should turn off the device and contact Vitalograph support. |

| | |
|--|---|
| <p>Problem Fault Symptoms:</p> | <ul style="list-style-type: none"> • Internal Memory Full Error displays and the LED flashes RED.  |
| <p>Possible Solutions: (In probable order)</p> | <ul style="list-style-type: none"> • Internal memory is full. Upload stored recordings using the Webportal. |
| <p>Problem Fault Symptoms:</p> | <ul style="list-style-type: none"> • Insert SD Card symbol (Green) displays and the LED flashes RED.  |
| <p>Possible Solutions: (In probable order)</p> | <ul style="list-style-type: none"> • The SD Card is full. Replace the SD Card. • An SD Card is required but not inserted. Insert an SD Card. |
| <p>Problem Fault Symptoms:</p> | <ul style="list-style-type: none"> • Remove SD Card symbol (Red) displays and the LED flashes RED.  |
| <p>Possible Solutions: (In probable order)</p> | <ul style="list-style-type: none"> • Internal memory (not the SD Card) is to be used for the recording. Remove the SD Card. |
| <p>Problem Fault Symptoms:</p> | <ul style="list-style-type: none"> • Device is connected to the PC via the USB cable but is not discovered by the Vitalograph Webportal. |
| <p>Possible Solutions: (In probable order)</p> | <ul style="list-style-type: none"> • Power off the device before connecting to the PC. • Login into the Webportal with an authorised login. • The PC does not have sufficient administration rights to install the required drivers. Contact your IT administration. • Contact support. |

| | |
|--|--|
| <p>Problem Fault Symptoms:</p> | <ul style="list-style-type: none"> • On start-up the amber warning symbol with “Rec Failed” appears and the LED Flashes RED.  |
| <p>Possible Solutions: (In probable order)</p> | <ul style="list-style-type: none"> • Recording was interrupted and the device powered down. Press select (forward keypad arrow) to acknowledge the notification and to resume normal device operation. |
| <p>Problem Fault Symptoms:</p> | <ul style="list-style-type: none"> • Real Time Clock symbol displays and the LED flashes RED.  |
| <p>Possible Solutions: (In probable order)</p> | <ul style="list-style-type: none"> • The Real Time Clock was not set/reset. If recording, shut down the device using the key. If not recording, press Select (forward arrow key) to resume normal operation. Reconfigure the date/time on the device. |
| <p>Problem Fault Symptoms:</p> | <ul style="list-style-type: none"> • Buzzer beeps loudly and warning displays remaining recording time. |
| <p>Possible Solutions: (In probable order)</p> | <ul style="list-style-type: none"> • Occurs when the key is used to turn the device off during a recording. • Turn the key so the power switch is back in the 'ON' position to resume the recording. • Press Select (forward keypad arrow/mute button) to end the recording and shut down the device. If the device is left for 10 seconds, it will shut down automatically and the recording will immediately end. |

Problem Fault Symptoms:

- **Device freezes during configuration or data upload.**

Possible Solutions:
(In probable order)

- Ensure battery pack is disconnected from the device when connected to the Vitalograph Web portal.
- To continue configuration, turn the device off and on again.
- To restart data upload, disconnect then reconnect USB data cable
- Reconfigure or restart data upload

Note: Contact details are listed at the start of this manual for assistance with set up, use or maintenance of equipment or to report unexpected operation or events concerning your Vitalograph device.

Warning: No modification of this equipment is allowed. Any unauthorised changes to the VitaloJAK may compromise product safety and/or data and as such Vitalograph cannot be held responsible and the device will no longer be supported.

9.1. Software Check

Information about the software can be obtained from the About box. This information may be required when contacting Vitalograph support or the clinical trials project team.

To access the About box:

1. Turn on the device using the key.
2. Wait until main menu displays.
3. Select 'Setup' then 'About'.

9.2. Product Useful Life Check

To ascertain whether the device has exceeded its useful life, Vitalograph recommend checking the clock battery. Failure of the clock battery will cause the device date/time to reset to a default setting.

10. Customer Service

The VitaloJAK device has no serviceable parts.

Devices and specified components must be returned to the manufacturer at the end of a Study as per Section 12 Disposal. All used components must be kept until the end of the study to allow investigation in case of any potential issues. Repairs should only be carried out by the manufacturer.

Customer Service contact for study sites using VitaloJAK is with the project team and site support. Details are provided in site manuals. Any serious incident that has occurred in relation to the device should be reported to Vitalograph and authorities in the country of use. Refer to Vitalograph contact information at the start of this manual.

11. Consumables and Components

Consumables and components for the VitaloJAK are study specific and should be ordered as resupply items as detailed in the Site Manual per study.

The following are standard part numbers for use by the clinical trial project management team.

| Cat. No | Description |
|---------|---------------------------------------|
| 71214 | Test Kit |
| 71215 | Test Kit with SD Card |
| 71216 | Test Kit with Short Cable |
| 71217 | Test Kit with SD Card and Short Cable |
| 71210 | Site Kit |

12. Disposal Instructions

Devices and used components including chest sensor/air microphone assemblies and used battery packs must be kept until the end of the study to allow investigation in case of any potential issues.

VitaloJAK devices, components and consumables including data cables, pouches, keys, screwdrivers and unused test kits should be returned to the manufacturer after use.









At the end of the study:









- Used chest sensor/ air microphone assemblies may be disposed of according to local guidance for disposal of healthcare waste.
- Used batteries may be disposed of according to local guidance for disposal of batteries.



Return shipment instructions are included in the study site manual.

Note: Do not dispose of these products as unsorted municipal or general waste.











13. Explanation of Symbols



| Symbol | Description |
|--|--|
|  | Type BF equipment |
|  | Class II |
| VA | Power rating |
| V  | Direct current |
|  | Instructions for Use; operating instructions |
|  | Manufacturer |
|  | Date of Manufacture (include date in format yyyy-mm-dd) |
|  | USB connector |
|  | The device must be taken to separate collection at the product end-of-life. Do not dispose of these products as unsorted municipal waste |
|  | Keep Dry |

| | |
|---|---|
|  | Do not re-use |
|  | Non sterile |
|  | Recycle |
|  | QR code - matrix bar code. All information in the bar code is included in the text under it |
|  | General warning sign (yellow) |
| IP22 | Ingress Protection rating – IP22, protection against solids >12.5mm and vertically dripping water when the enclosure is tilted at an angle up to 15° from its normal position |
|  | MR Unsafe |
| MD | Medical Device |
|  | Country of Manufacture |
| Rx Only | Restricted to sale by, or on the order of a physician |
| SN | Serial number |
| REF | Catalogue number |
|  | Use by date (sensor only) |
| LOT | Batch code (sensor only) |



| | |
|---|------------------------------|
|  | Model Number |
|  | Unique Device Identification |

13.1. Graphical User Interface Symbols

| Symbol | Description |
|---|---|
|  | Recording in progress |
|  | Where the mute function is enabled, symbol displays when the mute button is pressed /At end of recording this symbol displays briefly before the device shuts down. |
|  | SD Card Full / Insert SD Card (green) |
|  | Remove SD Card (red) |
|  | Attach Cover |
|  | Low Battery (red) |
|  | Insert Cable / Cable Error (amber) |
|  | Recording Failed / Device Idle (amber) |
|  | Internal Memory Full / Invalid Configuration (purple) |
|  | Device is connected to a PC in Remote Mode (blue) |

| | |
|---|--------------------------------|
|  | Memory error (blue) |
|  | Real time clock error (purple) |

13.2. Additional Symbols Used on Device

| Symbol | Description |
|---|--------------------|
|  | Cable Connection |
|  | Battery Connection |

14. Description of the Vitalograph Model 7100 VitaloJAK

The VitaloJAK provides the means to sense voice and cough activity from a subject, record this information and store it to an SD memory card or to internal memory for later playback, review, and analysis of the cough sounds on a windows based PC.

The data is uncompressed so that no information is lost due to data compression methods. The VitaloJAK is capable of recording 24hrs worth of information continuously without the need to replace the battery pack.

The sensing of the coughs is provided by an air-coupled Electret Condenser Microphone (ECM) Cough Sensor on a single channel for analysis data recording. A second channel is also recorded; this channel uses a microphone to sense audio data. The purpose of the audio data is to provide a monitoring or supervisory channel in order to determine the validity of the data recorded from the Cough sensor channel.

The VitaloJAK model 7100 is a non-invasive battery operated device intended to acquire, record and store ambulatory cough sounds from patients for up to 24 hours. The device stores the data on internal or removeable memory card media for later playback, review, and analysis on a windows based PC.

15. Technical Specifications

| | |
|--|---|
| Product | Vitalograph VitaloJAK, Model 7100 |
| Essential Performance | Recording the audio inputs from the Cough Sensor and Microphone |
| Essential Performance Test Limits | Recordings are downloaded to a PC for subsequent analysis by trained Audio Analysts. A valid sound recording must be present on one of the channels (either Cough Sensor or Microphone) to perform audio analysis. Minimum requirement for a valid audio file for EN60601 testing is no flat line data, indicating no audio was recorded. |
| Maximum test duration | 24 hours, using 3 x AA Alkaline battery pack |
| Operating temperature range | 5 – 40°C |
| Operating humidity range | 15% – 90% |
| Atmospheric pressure | 700 – 1060hPa |
| False Positive Cough Rate | None (coughs are manually identified) |
| Safety standards | EN 60601-1:2006+A1:2013+A2:2021 |
| Home Healthcare Standard | EN 60601-1-11:2015+A1:2021 |
| EMC Standards | EN 60601-1-2:2015+A1:2021 |
| QA/GMP standards | EN ISO 13485, SOR/98-282 & FDA 21 CFR 820 |
| Dimensions | 78mm x 108mm x 32mm (device) |
| Weight | 165g – device only 240g – device with battery pack, 349g – device with battery pack, sensor and pouch |

| | |
|-----------------------|---|
| Communications | <p>SD Card</p> <p>USB 2.0/3.0 for data download and device configuration. Custom USB cable is required, supplied as part of Site Kit (71210)</p> |
| Power Supply | <p>1 x Battery Pack containing 3 x AA Alkaline Batteries.</p> <p>USB powered during configuration/download 5V/500mA.</p> |
| IP Rating | <p>IP22 (protected against touch by fingers >12.5mm and water spray <15 degrees from vertical).</p> |
| Product Life | <p>10 years+. No service or maintenance required as this is a trial/study device with no serviceable parts and the device is returned to the manufacturer at the end of the trial/study.</p> <p>Reference section 9.2 'Product useful life checks' for information on how to ascertain whether the device has exceeded its useful life.</p> |
| Memory | <p>SD Card, Size: min 4GB sufficient for 24-hour recording</p> <p>Internal Memory: 32GB sufficient for 10 days of 24-hour recordings.</p> <p>Write speed: 20 MB/sec</p> |
| Sampling Rate | <p>8 kHz</p> |

| | |
|--|---|
| User Interface | LCD – 1.77” 4 button keypad for device configuration and event marking On/off key switch On board buzzer Bi-colour LED to indicate device state |
| PC Specification for Web Portal | PC running windows 7 or later. 1GB RAM Dual Core CPU, min 2GHz Display, min resolution of 1280 x 768 pixels Google Chrome browser, version 57 or later |

Notes:

- The operating conditions specified apply to the device.
- The VitaloJAK sensor is a type BF applied part.
- An applied part is a part of the equipment, which in normal use necessarily comes into physical contact with the subject for equipment or system to perform its function.

16. Electromagnetic Compatibility (EMC) Standards

Marking by the symbol  indicates compliance of the Vitalograph Model 7100 VitaloJAK to the Medical Devices Directive of the European Community.

The Model 7100 VitaloJAK has been tested in accordance with:
 EN60601-1:2006+A1:2013+A2:2021 - Medical electrical equipment.
 General requirements for basic safety and essential performance

EN 60601-1-2:2015+A1:2021 Medical electrical equipment - Part 1-2: General requirements for basic safety and essential performance - Collateral Standard: Electromagnetic disturbances - Requirements and tests.

EN 60601-1-11:2015+A1:2021 - Medical electrical equipment – Part 1-11: General requirements for basic safety and essential performance – collateral standard: Requirement for medical electrical equipment and medical electrical systems used in the home healthcare environment.

EN 60601-1-2:2015+A1:2021 - Emissions tests

| Emissions test | Compliance | Electromagnetic environment - guidance |
|--------------------------|-------------------|--|
| RF emissions CISPR 11 | Group 1 | The Model 7100 VitaloJAK uses RF energy only for its internal function. Therefore, its RF emissions are very low and are not likely to cause any interference in nearby electronic equipment. |
| RF emissions CISPR 11 | Class B | The Model 7100 VitaloJAK is suitable for use in all establishments, including domestic establishments and those connected to the public mains network (e.g. at home and doctor's offices in residential areas) |

EN 60601-1-2:2015+A1:2021 - Immunity tests

| Immunity test | Test level | Compliance level Reached |
|---|--|--|
| Electrostatic discharge (ESD) EN 61000-4-2 | Contact: ± 8 kV Air: ± 2 kV, ± 4 kV, ± 8 kV, ± 15 kV | Contact: ± 8 kV Air: ± 2 kV, ± 4 kV, ± 8 kV, ± 15 kV |
| Power frequency (60Hz) magnetic field IEC 61000-4-8 | 30A/m | 30A/m |
| Radiated RF EN 61000-4-3 | 10 V/m 80MHz to 2700MHz | 10 V/m 80MHz to 2700 MHz |

| | | |
|--|---|--|
| Proximity fields from RF devices EN 61000-4-3 | 9 to 28V/m 385 to 5785MHz As per Table 9 EN60601-1-2:2015 | 9 to 28V/m 385 to 5785MHz As per Table 9 EN60601-1-2:2015 |
| Proximity magnetic Fields EN 61000-4-39 | 8A/m 30kHz 65A/m 134.2kHz (2.1 kHz PM) 7.5A/m 13.56MHz (50 kHz PM) | 8A/m 30kHz 65A/m 134.2 kHz (2.1 kHz PM) 7.5A/m 13.56 MHz (50 kHz PM) |

Electrostatic Discharge Warning: Although the VitaloJAK is designed to be unaffected by typical electrostatic discharge (ESD) when in recording mode and in its pouch, when the device is not in its pouch very high levels of ESD can result in a temporary suspension of normal operation, requiring the operator to turn the device off/on or disconnect/reconnect the USB data cable to resume normal operations.

Use of components and consumables other than those specified or provided by Vitalograph for this equipment could result in increased electromagnetic emissions or decreased electromagnetic immunity of the VitaloJAK and result in improper operation.

Portable RF communications equipment (including peripherals such as antenna cables and external antennas) should be used no closer than 30 cm (12 inches) to any part of the VitaloJAK including cables specified by Vitalograph. Otherwise, degradation of the performance of this equipment could result.

Medical electrical equipment needs special precautions regarding EMC and needs to be installed and put into service according to the EMC information provided.

Warning: No modification of this equipment is allowed.

17. FDA Notice

Caution: Federal Law restricts this device to sale by, or on the order of a physician.

18. Regulatory information

Product: Model 7100, VitaloJAK

Vitalograph hereby ensures and declares that the above product associated with these instructions for use, is designed and manufactured in accordance with the following QMS regulations and standards:

- European Medical Devices Directive (MDD) 93/42/EEC, as amended.

This device is classified as IIa per Annex IX of the MDD also meets the provisions of the Essential Requirements, Annex I, via compliance with Annex II of the Medical Devices Directive as per Article 11, section 3a, excluding point 4 of Annex II.

- Canadian Medical Device Regulation SOR/98-282
- FDA Quality System Regulation (QSR) 21 CFR 820
- EN ISO 13485 Medical devices. Quality management systems. Requirements for regulatory purposes.

Certifying Body: British Standards Institute (BSI).

BSI Notified Body #: 2797

Certificate Nos. CE 00772, MD 82182

Signed on behalf of Vitalograph (Ireland) Ltd.



Frank Keane.

CEO, Vitalograph Ltd.

19. Guarantee

Subject to the conditions listed below, Vitalograph Ltd. and its associated companies, (hereinafter called the Company) guarantee to repair or at its option replace any component thereof, which, in the opinion of the Company is faulty or below standard as a result of inferior workmanship or materials.

The conditions of this Guarantee are:

1. This Guarantee shall only apply to hardware defects which are notified to the Company or to its accredited distributor within 1 years of the date of purchase of the equipment, unless otherwise agreed in writing by the Company.
2. Software (meaning computer software, or user installable modules) is guaranteed for 90 days from the date of purchase.
3. The Company warrants that the software when correctly used in conjunction with the hardware will perform in the manner described in the Company's literature and user manuals. The Company undertakes to rectify at no expense to the customer any software failure notified within the period stated above, provided that the failure can be recreated and the software has been installed and used in accordance with the user manual. Notwithstanding this clause, the software is not warranted to be free of errors.
4. This Guarantee does not cover any faults caused by accident, misuse, neglect, tampering with the equipment, use of consumable items or parts not approved by the Company, or any attempt at adjustment or repair other than by personnel accredited by the Company, nor does it cover reinstatement of any configuration changes caused by the installation of any software.
5. If a defect occurs please contact the supplier from it was purchased for advice. The Company does not authorize any person to create for it any other obligation or liability in connection with Vitalograph equipment.
6. This Guarantee is not transferable and no person, firm or company has any authority to vary the terms or conditions of this guarantee.
7. To the maximum extent permitted by law, the Company does not accept liability for any consequential damages arising out of the use of, or inability to use any Vitalograph® equipment.
8. This Guarantee is offered as an additional benefit to the Consumer's statutory rights and does not affect these rights in any way.

